

BIS Sprinkler Clamp TA41

(B 12 15)

for sprinkler pipes 23 - 221 mm

M10 - M12



Features and Benefits

- one-part clamp
- for sprinkler pipes up to 8" (221 mm)
- with knurled nut for fixing to stud bolt or threaded rod
- material: steel
- clamp: pre-galvanized; nut: zinc plated
- with FM approval - certificate number 3024336
- UL listed - certificate number VFXT.EX9140



Cert.Nr.
3024336



Cert.Nr.
VFXT.EX9140

Part No.	D (mm)	D (°)	DN (mm)	G	H (mm)	h (mm)	b x s (mm)	t1 (mm)	Fa,z (N)	FM	UL	Pack 1
453 5 021	23	1/2	15	M10	86	51	16 x 1,0	40	1,500	FM	UL	100
453 5 027	28	3/4	20	M10	86	48	16 x 1,0	34	1,500	FM	UL	100
453 5 034	35	1	25	M10	89	48	16 x 1,0	30	1,500	FM	UL	100
453 5 042	44	1 1/4	32	M10	98	52	16 x 1,0	30	1,500	FM	UL	100
453 5 048	50	1 1/2	40	M10	105	56	16 x 1,0	31	1,500	FM	UL	100
453 5 060	62	2	50	M10	117	61	16 x 1,0	30	1,500	FM	UL	100
453 5 076	77	2 1/2	65	M10	130	68	22 x 2,0	29	4,500	FM	UL	50
453 5 089	90	3	80	M10	143	74	22 x 2,0	28	4,500	FM	UL	50
453 5 114	115	4	100	M10	175	93	22 x 2,0	35	4,500	FM	UL	25
453 5 140	142	5	125	M12	213	111	25 x 3,0	40	5,200	FM	UL	20
453 5 168	170	6	150	M12	250	132	25 x 3,0	48	5,200	FM	UL	15
453 5 219	221	8	200	M12	312	167	25 x 3,0	56	5,200	FM	UL	10

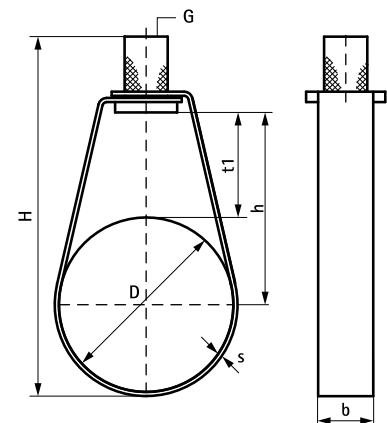

Complementary

BIS Beam Clamp Model C
BIS Roofing Sheet Hanger VdS

Alternative

BIS Sprinkler Clamp MX-SM